

TWISTER

SMONTAGOMME AUTOMATICO
AUTOMATIC TIRE CHANGER

TUTTA LA POTENZA DEL CAMBIO PNEUMATICI IN UN'UNICA SOLUZIONE
ALL THE POWER OF TIRE CHANGING IN ONE SOLUTION



- ✓ **Stallonatore elettrico brevettato**: una forza costante
- ✓ Sistema a flessibilità controllata **easy-to-use**
- ✓ Nuova tecnologia costruttiva **high density**
- ✓ Bloccaggio cerchi **high quality brevettato**
- ✓ Bloccaggio cerchi:
EXT: 12"-26" pollici
INT: 14"-28" pollici
- ✓ **Patented electric bead breaker**: a constant force
- ✓ **Easy to use** flexibility control system
- ✓ New **high density** engineering
- ✓ **Patented high quality** locking system of the rims
- ✓ Rim clamping:
EXT: 12"-26" inches
INT: 14"-28" inches

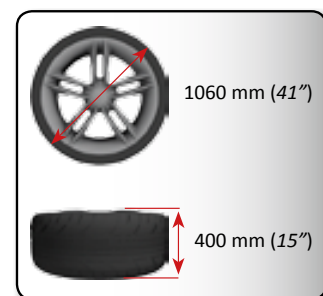

. 20011000 +
. 20011133 (Press System)

femas

FEMAS AUTOMOTIVE EQUIPMENT S.R.L.

SINCE 1977 THE MADE IN ITALY



HELICAL SWING

Dispositivo di gonfiaggio a pedale incorporato.
Integrated foot-controlled inflating system.

PATENTED

Piatto autocentrante 12"-28" pollici

- Doppio senso di rotazione a due velocità (motoinverter).
- Bloccaggio interno ed esterno del cerchio.
- Griffe a elevata capacità di serraggio azionate da due cilindri.

Self-centering table 12"-28" inches

- Two-way rotation with 2 speed selector (motoinverter).
- Inner and outer rim clamping.
- High clamping capacity driven by two cylinders.

Tutti i comandi a portata di... piede!

4 robusti pedali in lega di alluminio per comandare con facilità le principali funzioni dello smontagomme e avere tutto sempre sotto controllo.

All the machine controls... at your feet!

4 strong aluminum alloy pedals to control easily the main functions of the tire changer and keep everything under control.



+30% POWERFUL

Stallonatore Elettrico brevettato

- Regolabile in *qualsiasi* posizione. Massima flessibilità! • Apertura a doppia velocità.
- Forza di stallonamento elettrica. • Paletta snodabile per adattarsi a ogni tipo di cerchio.
- Una vasta gamma di accessori fra cui la pratica rulliera basculante, a pavimento e le protezioni per paletta.

Patented Electric Bead Breaker

- Adjustable in any position. Maximum flexibility! • Double speed in opening.
- Electric bead breaking force. • Jointed blade to fit in all type of rims.
- Wide range of optionals as the tilting roller table, floor roller table and the bead breaker protection.

Sistema di bloccaggio del palo a 2 posizioni con allontanamento automatico dal cerchio.

2-position tool locking with automatic setting of appropriate distance from the rim.

PATENTED

Cambio rapido con utensile standard incluso!

- Dotato di inserti di protezione per cerchi in lega.
- Regolabile per adattarsi a ogni tipo di cerchio!



Quick clutch with tool head included!

- Integrated protection for alloy rim.
- Adjustable to fit every type of rim perfectly!



ELECTRIC POWERED

EXCLUSIVE! PATENTED BREVETTATO



Dispositivo premi-tallone

- Agilità e robustezza per una valida assistenza all'operatore.
- Massima libertà di regolazione.
- Il tampone segue automaticamente lo pneumatico durante la rotazione per una pressione costante.

Bead pressing device

- Strength and agility to ensure a valid assistance to the operator.
- Maximum adjusting agility.
- The plug follows automatically the tire during the rotation to ensuring a constant pressure

OPTION

Sollevatore pneumatico con comando a pedale

- Portata di 60 Kg.

Pneumatic foot-controlled wheel lifter

- 60 Kg lifting capacity.

OPTION



20011150 WHEEL LIFTER



OPTIONS

Rulliera basculante e a pavimento

- Agevolano le operazioni di stallonamento!

Tilting roller table and floor roller table

- Make bead breaking operations easier!

DOPPIA VELOCITÀ DI LAVORO

TWO SPEEDS WORKING

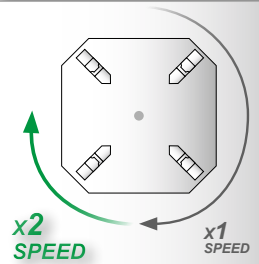

LONG LIFE RUBBER PAD!



Tampone reversibile
Reversible rubber pad

EXCLUSIVE



Il **Twister** è uno smontagomme automatico capace di operare su cerchi dai 12" ai 28" pollici. Ideale per autovetture e veicoli commerciali leggeri, è in grado di operare anche su pneumatici UHP, ribassati, run-flat e da moto (adattatori in opzione). Robusto in ogni suo aspetto e con un profilo ergonomico, con palo a movimento elicoidale e sistema di bracci **Press System** (opzionali), è un'eccezionale combinazione fra tecnologia, efficienza e praticità d'uso grazie anche all'esclusivo **stallonatore elettrico** brevettato.

Twister is an automatic tire changer able to work on rims from 12" to 28" inches. Ideal for cars and light commercial vehicles, it can also operate on UHP tires, low profile tires, run-flat and motorcycle wheels (optional adapters). The Twister tire changer is heavy-duty engineered in all its aspects: with its ergonomic profile, the helical swinging of the pole and its **Press System** arms (option), it is a powerful blend of technology, efficiency and easy handling, thanks also to the patented **electric bead breaker**.

ACCESSORI / ACCESSORIES

INCLUSI / STANDARD



30010577
Protezione paletta stallonatore
Bead breaker protection



30010235
Leva alza-talloni WDK
WDK Bead lever



20010237
Set protezioni griffe
Clamps protection set



3005116
Parabordo
Rim Protection



Cambio rapido integrale
Quick clutch with tool



Protezioni utensile standard
Standard tool protections

OPZIONALI / OPTIONS



2002206
Rulliera a pavimento
Floor roller table



20010525
Rulliera basculante
Tilting roller table

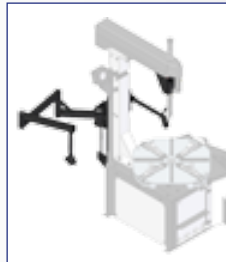

20011133 PRESS SYSTEM
Bracci pneumatici
premi-tallone.
*Pneumatic arm for
bead pressing assist.*



2003632
Attacco rapido per utensile (7°)
Quick change tool hub (7°)



20011511
Adattatori ruote moto 4"-21"
Adaptors for motorbikes 4"-21"



20011565
Kit protezioni + spessori moto
Protection + spacers for motorbikes

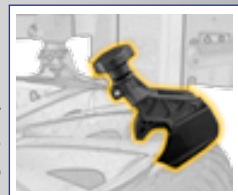

30010234
Morsetto premi-tallone
Bead pressing clamp



20010525
Utensile ruote scooter 8"
Scooter tool head 8" rim



2403683
Utensile integrale in plastica
Full plastic tool head

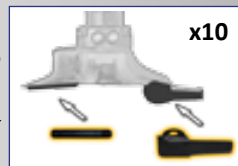

20010236
Kit protezioni utensile standard
Standard tool protections kit

Questi riportati sono solo alcuni esempi. Per ulteriori accessori consultate i nostri listini.

Here are a few examples. Please see our price list for more accessories.



www.femasrl.com

DATI TECNICI	TECHNICAL DATA	TWISTER
Bloccaggio cerchi (pollici)	Rim clamping (inch)	EXT: 12"-26" INT: 14"-28"
Diametro massimo pneumatico	Max. tire diameter	1060 mm (41")
Larghezza max. cerchio	Max. rim width	400 mm (15")
Alimentazione elettrica	Electric power supply	200-230 V 50-60 Hz 1Ph 0,75 kW
Pressione d'esercizio	Operating pressure	8 - 10 bar
Rotazione massima del piatto	Self-centring table max. speed	7 rpm (min.) - 14 rpm (max.)
Stallonatore elettrico (forza)	Electric Bead breaker (power)	Elettrico / Electric (1.600 Kg - 15.690 N)
Sistema di gonfiaggio	Inflating system	a pedale / foot controlled
Pressione di gonfiaggio massima	Max. inflating pressure	3,5 bar (50 PSI)

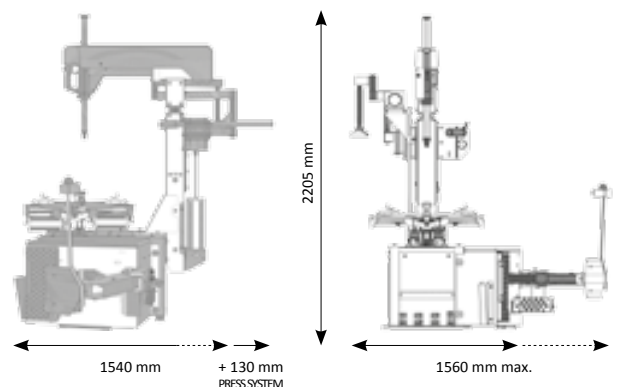

FEMAS s.r.l.
via D. Gaiti 23
42015 Correggio (RE) Italy
Tel. +39 0522 693 885
Fax +39 0522 693 961
info@femasrl.com
www.femasrl.com



Le caratteristiche tecniche e gli allestimenti presentati in questo prospetto possono subire variazioni. Le immagini riprodotte non sono vincolanti. Una parte delle macchine è illustrata con dispositivi opzionali disponibili previo pagamento di un sovrapprezzo. Con riserva di modifiche tecniche e visuali.

Technical data and composition presented in this catalogue may vary. Pictures reproduced are only indicative. Some machines are illustrated with optional extras which are available at extra cost. Technical and visual modifications reserved.

© 2016 Femas s.r.l. - All rights reserved